

XSERIES

**MOBILE FALL
PROTECTION SYSTEM**

INSTRUCTION MANUAL



www.highworx.ie

Innovative Workplace Solutions

+353 (0) 1 5563424 • sales@highworx.ie

X1240 X1250

INSTRUCTION MANUAL

These instructions apply to the following model(s): X1240 & X1250

Manual Revision Date: 10 August 2018

Please visit www.Highworx.ie for the latest user instruction manual revision available for this product offering as well as supporting documentation.

X1240

X1250

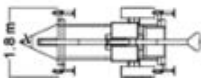
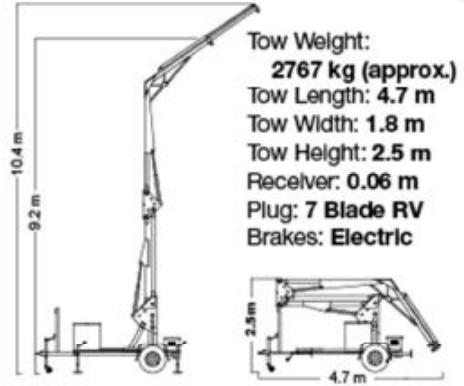
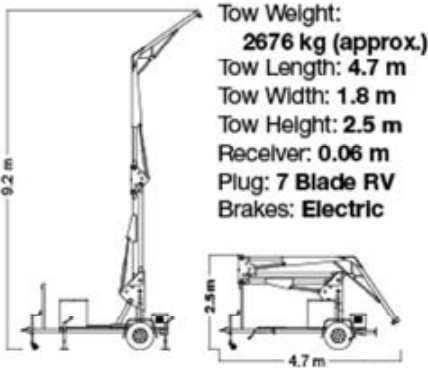

TABLE OF CONTENTS

General	4
Warnings & Limitations	5-9
Positioning the Unit	10
Maintenance Schedule	11
Deep Cycle Battery Maintenance	13-13
General Operation	13
Initial Setup & Operation	14-16
Mast Syncing	17
Safety Instructions	17-18
Inspection	18-20
Limited Warranty	22
Warranty Registration Card	23
Declarations of Conformity	24-25

GENERAL

The *X-series 1240 & 1250* is a mobile fall protection system. It is intended to provide an anchor point for working at height.

The unit is comprised primarily of A36 steel and also includes (but not limited to) rubber, plastics, copper, concrete, hydraulic fluid, and battery components.

Fall protection systems are designed for use where fall hazards exist.

The *X-series 1240 & 1250* Fall Protection System is a mobile engineered anchorage solution designed to protect workers from fall hazards.

The application/operation of the *X-series 1240 & 1250* is further detailed under the topics of LIFTING THE UNIT, GENERAL OPERATION, INITIAL SETUP & OPERATION, and MAST SYNCING. Users must abide by the limitations for the X1240 & X1250 under the topic WARNINGS & LIMITATIONS.

The usable life of this product is indefinite as long as the product passes *inspection*

WARNING

X-series systems shall be a part of a complete fall protection system.

If the user chooses to disregard this warning, he or she is solely responsible for the safety of the entire system and all users.

Prior to replacing or modifying any components to a fall protection system, consult *Manufacturer*.

Any changes to this system must be authorized by *Manufacturer* in writing.

Operators must read and understand all instructions fully; failure to do so could result in a serious or fatal injury.

To achieve the maximum level of safety that this system is capable of providing, all instructions must be followed diligently.

This means careful planning of your application and work method.



WARNING

You assume complete liability if you fail to follow these instructions and become injured. Use this system only as instructed.



WARNING

Check any medical conditions that may affect the safety of the equipment user in normal and emergency use.

WARNINGS & LIMITATIONS

Equipment shall only be used by a person trained and competent in its safe use.

A rescue plan shall be in place to deal with any emergencies that could arise during work.

Do not make alterations or additions to the equipment without the manufacturer's prior written consent, and that any repair shall be carried out in accordance with the manufacturer's procedures.

X-series 1240 & 1250 shall not be used outside of its limitations, or for any purposes other than that for which it is intended.

This equipment should NOT be a personal issue item.

Use only *Manufacturer* approved hardware with this product.

Use only compatible locking snap hooks or locking carabiners with this product.

The *X-series 1240 & 1250* is designed for use with EN approved *retractables & components* only. Substitution or replacement with non-approved components will endanger the compatibility within the system and may affect the reliability and safety of the total system.

Inspect for dangers that may arise by the use of combinations of items of equipment in which the safe function of any one item is affected by or interferes with the safe function of another.

User must carry out a pre-use check of the equipment, to ensure that it is in a serviceable condition and operates correctly before each use.

All equipment must be inspected before each use. Any component exhibiting deformities, unusual wear, or deterioration must be immediately discarded.

The pre-use check can be further explained under the topic INITIAL QUALITY INSPECTION. This section includes the features of the equipment that require the pre-use check, the method of checking, and the criteria against which the user can decide whether or not the equipment is defective.

It is essential for safety that equipment is withdrawn from use immediately should any doubt arise about its condition for safe use or it has been used to arrest a fall. Unit must not be used again until confirmed in writing by a competent person that it is acceptable to do so.

SURFACE GRADE: The *X-series 1240 & 1250* is designed for use on surfaces that allow the unit to be leveled within 2° horizontal and vertical to grade.

Warning: Do not use on surfaces that do not allow the unit to be leveled within 2° horizontal and vertical to grade.

Only use EN approved SRLs and connectors.

Attach SRL to the back D-Ring of harness only.

It is essential for safety that the anchor device or anchor point should always be positioned, and work carried out in such way, as to minimize both the potential for falls and potential fall distance. The anchor device/point is to be placed above the position of the user.

A full body harness is the only acceptable body holding device that can be used in a fall arrest system.

Verify the free space required beneath the user at the workplace before each occasion of use, so that, in the case of a fall, there will be no collision with the ground or the other obstacle in the fall path.

Consider hazards that may affect the performance of the equipment and corresponding safety precautions that have to be observed (e.g.: extremes of temperature, trailing or looping of lanyards or lifelines over sharp edges, chemical reagents, electrical conductivity, cutting, abrasion, climatic exposure, pendulum falls).

The unit should only be moved with a tow vehicle, or other suitable moving device.

PRODUCT LABELS

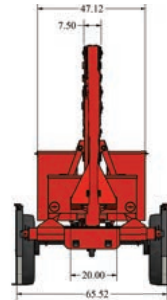
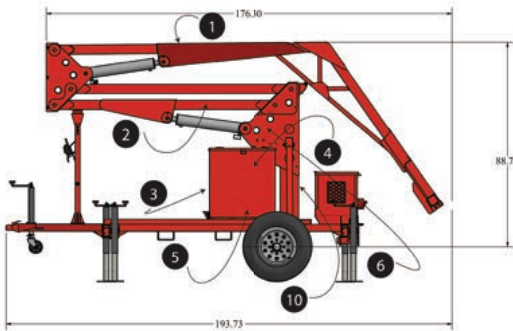

EN 795:2012 Type B III
TS 164 15:2013

IV CE 0082 Manufactured in the USA
MAXIMUM USERS PERMITTED
SIMULTANEOUSLY: 2 USERS

MOBILE FALL
PROTECTION SYSTEM
MALTDYNAMICS.COM



Model: _____
V.I.N.: _____
GVWR: _____
Tire Size: _____
Date of Mfg.: _____

I - Model Number II - Manufacturer's Name

III - Applicable Standard IV - CE Marking Dimensions: 13.12 mm x 9.31 mm

V - V.I.N. / Serial Number

Labels are in the same configuration on models X1240 and X1250, while both conforming to the EN 795: 2012 Type B standard.

EC type examination carried out by APAVE SUDEUROPE SAS – CS60193 – 13322 MARSEILLE CEDEX 16 – France
Notified body CE0082.

C2 production control is carried out by APAVE SUDEUROPE SAS – CS60193 – 13322 MARSEILLE CEDEX 16 – France
Notified body CE0082.

Do not use if the system or any part of the system appears to be damaged.

Do not use the system if any components do not operate properly.

Personal fall arrest systems and components subjected to impact loading shall be immediately removed from service and shall not be used again for employee protection until inspected and determined by a competent person to be undamaged and suitable for reuse.

Use in highly corrosive or caustic environments dictates a more frequent inspection and servicing program to ensure the integrity of the system is maintained.

It is essential for the safety of the user that if the product is re-sold outside the original country of destination the reseller shall provide instructions for use, for maintenance, for periodic examination and for repair in the language of the country in which the product is to be used.

Use mild soap and water to clean the *X-series 1240 & 1250*. DO NOT use harsh abrasives or chemicals. The maintenance procedures are to be strictly adhered to.

If the *X-series 1240 & 1250* becomes wet, either from being in use or when due to cleaning, it shall be allowed to dry naturally, and shall be kept away from direct heat.

It is beneficial for the unit to be stored inside whenever possible.

Please follow the additional maintenance manual for specific, periodic maintenance. The maintenance manual can be found on the website Highworx.ie.

Perform regular periodic examinations; the safety of users depends upon the continued efficiency and durability of the equipment.

Periodic examination frequency shall be at least every 12 months.

Periodic examinations are only to be conducted by a competent person and strictly in accordance with the manufacturer's procedures.

Check the legibility of the product markings.

Any repair shall only be conducted by a competent person for repair, who has been authorized by the manufacturer, and that the repair procedure shall be strictly in accordance with the manufacturer's instructions.

The X1240 and X1250 are designed for up to 2 workers in any position for Fall Restraint or Fall Arrest.

Never use fall protection equipment for towing or hoisting.

The maximum load that can be transmitted in service from the anchor device to the structure is 13kn in a downward direction. Furthermore, the minimum required strength is 13 kn.

Do not raise the mast when wind speeds may exceed (12.5 m/s). If wind speeds exceed (12.5 m/s) when the mast is raised, lower the mast and do not continue to operate the machine.

Do not operate the machine in strong or gusty winds.

Always check for obstructions below the work area to make certain the potential fall path is clear.

Do not attempt to move the system while workers are attached.

Do not remove product labels.

When the anchor device is used as part of a fall arrest system, the user has to be equipped with a means of limiting the maximum dynamic forces exerted on the user during the arrest of a fall to the maximum of 6kn.

Failure to follow these instructions could result in a serious or fatal electrical incident.'

POSITIONING THE UNIT

CRANE TRANSFER: This unit comes with lifting lugs which should only be used for lifting purposes. It is the responsibility of the owner to have a lifting plan in place before attempting to lift the unit. Extreme caution must be taken at all times and the plan shall include the use of a spreader bar. Use only appropriately sized equipment to lift unit. Weight listed on unit is dry weight for base model only. Additional accessories, options, and equipment can increase this weight. It is the responsibility of the owner to verify lifting weight of unit before attempting to do so. Use extreme caution – failure to do so can lead to bodily harm or death.

FORKLIFT TRANSFER: To properly lift the unit with a forklift, use the built-in forklift pockets.

LOCATION: The area where the system is used must be no less capable of supporting the weight of the system and the loads applied by the system in event of a fall.

SYSTEM CAPACITY FOR X1240: The maximum number of users per unit is 2 (two). Only (1) user per individual anchor point is permitted.

SYSTEM CAPACITY FOR X1250 (Telescoping Model): The maximum number of users is 2 (two). Only (1) user per individual anchor point is permitted.

MOVING THE SYSTEM: Always disconnect workers before attempting to move the system. Never expose a worker(s) to a fall hazard by pulling the system while workers are connected.

WORKING DISTANCE: *WARNING: DO NOT EXCEED WORKING DISTANCE REQUIREMENTS.*

MAINTENANCE SCHEDULE

X-series 1240 & 1250 Maintenance & Inspection Schedule

Every Use (By Authorized User)	Monthly (By Authorized User)	6 Month (Competent Person Other than End User)	Item to Inspect
	x		Tire Pressure
x			Brake System Battery Check
	x		Grease Coupler
x	x	x	Labels
x	x	x	Main Power Disconnect
	x	x	Battery
		x	Battery Charger
x	x	x	Remote Control
	x	x	Hydraulic Tank
	x	x	Hydraulic Pump/Motor/Manifold
	x	x	Hydraulic Hoses/Lines
x	x	x	Upper Cylinder
x	x	x	Lower Cylinder
x	x	x	All Hydraulic Connections
x	x	x	Manual
	x	x	Grease Fittings
x	x	x	Anchor Points (Bolts & Swivel)
		x	Torque Bolts

An in depth Maintenance Manual for the XSERIES is available *please contact www.Highworx.ie*

DEEP CYCLE BATTERY MAINTENANCE

WARNING

When charging the unit's battery, always do so with the battery box lid open as this allows for venting of both gases and heat.

WARNING

This product contains a chemical known to the state of California to cause cancer, birth defects, or other reproductive harm.

1. New batteries should be given a full charge before use.
2. Battery cables should be intact, and the connectors kept tight at all times. Always use insulated tools to avoid shorting battery terminals. Regular inspection is recommended.
3. Vent caps should be correctly installed and tight during operation.
4. Batteries should be kept clean and free of dirt and corrosion at all times.
5. Batteries should always be watered after charging unless plates are exposed before charging. If exposed, plates should be covered by approximately 3.2 mm of electrolyte (add distilled water only). Check electrolyte level after charge. The electrolyte level should be kept 6.4 mm below the bottom of the fill well in the cell cover.
6. Water used to replenish batteries should be distilled or treated not to exceed 200 T.D.S. (Total Dissolved Solids... parts per million). Particular care should be taken to avoid metallic contamination (iron).
7. For best battery life, batteries should not be discharged below 80% of their rated capacity.
8. Avoid charging at temperatures above 48 degrees C or ambient, whichever is higher.
9. Always use the provided matched charger and battery pack system. Unmatched chargers will cause potential problems.
10. As batteries age, their maintenance requirements change. This means longer charging time and/or higher finish rate (higher amperage at the end of the charge). Usually older batteries need to be watered more often... and their capacity decreases.
11. Lead acid batteries like the ones used in the unit should be brought up to full charge at the earliest opportunity. Avoid

- continuously operating batteries in a partially charged condition. This will shorten their life and reduce their capacity.
12. Extreme temperatures can substantially affect battery performance and charging. Cold reduces battery capacity and retards charging. Heat increases water usage and can result in overcharging. Very high temperatures can cause “thermal run-away” which may lead to an explosion or fire. If extreme temperature is an unavoidable part of an application, consult a battery/charger specialist about ways to deal with the problem.
 13. Inactivity can be extremely harmful to all lead acid batteries. If season use is anticipated, we recommend the following:
 - i. Completely charge the battery before storing.
 - ii. Remove all electrical connections from the battery, including series/parallel connectors.
 - iii. Store the battery in as cool a place as possible. However, do not store in a location which will consistently be below 0 degrees C. Batteries will discharge when stored, the lower the temperature the lower the self-discharge.
 - iv. When not in use, boost every two months.

GENERAL OPERATION

Don a full body harness according to the manufacturer’s instructions.

Install only EN compliant self-retracting devices (SRL’s) and personal fall protection according to the manufacturer’s instructions supplied with that product.

WORKING AREA/USE: When using the unit, the walking/working surface being accessed by the user must be of a sufficient height as not to allow any part of a worker’s body to strike an object, or, the next lower level, in the event of a fall arrest situation. The X-series 1240 & 1250 may be used up to 30 degrees off plumb in the East, West and South directions depending upon model and anchor points being used so long as the user cannot strike an object or the next lower level in a fall arrest. Please see diagrams below.

INITIAL SETUP & OPERATION

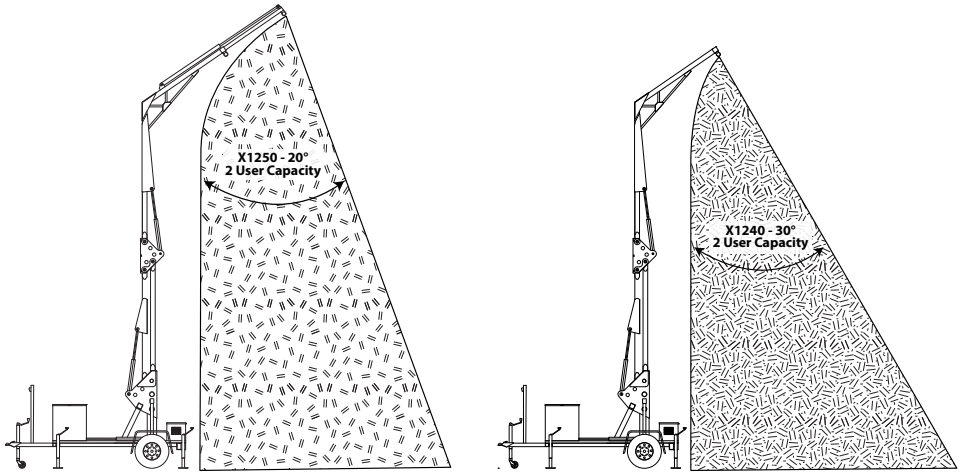

Before using the unit, be sure to read, understand, and follow the instructions that come with your system. Knowing how to use the system properly will greatly reduce the possibility of injury.



Before the first use of the X-series 1240 & 1250, it must be plugged in and charged 24 hours. The power switch must be in the “off” position before charging.

1. Using vehicle, position the unit as close as possible to working location. (Unit may also be positioned with the optional GO! System Friction Drive Mobility Package if so equipped.) When possible, place the system on a solid, level surface. The surface must be suitable for supporting the machine in the case of a fall. The unit may remain connected to the vehicle as long as all fall forces are absorbed by the unit. When positioning the unit, be sure to allow enough clearance for the mast to raise without interference.
2. Rotate jacks to the downward position.
3. Starting at the anchor-side of the machine, adjust the 2 outrigger jacks until the level indicator shows that the unit is level.
 - NOTE: The outrigger jacks, NOT the tires, must support the system’s weight. The tires may be in contact with the ground, but load must be on outriggers.
4. Moving to the tow-side of the machine, repeat the process in step 4 until the system shows level.
 - NOTE: Double check to ensure the system is level in both directions. The unit must be within 2 degrees of level before use.

WARNING

WARNING: Be sure to lower each jack correctly. Not doing so could hinder the performance of the machine and may cause serious or fatal injury.

5. Connect the controller to the connection point on control box located at the anchor-side of the unit. Turn the power switch to "ON".
6. Raise the anchor point of the mast to waist height by pressing the Mast Raise button.
7. Attach SRL(s) to anchor point(s) and attach tagline to SRL(s).
8. Raise Mast to the desired height by pressing Raise Mast button. Take note of overhead obstacles as well as required working distances. Once desired height is met, turn off main power and disconnect control pendant from the unit. Follow any lock out/tag out procedures required by your organization. Steps need to be taken to ensure that the unit will not be lowered while workers are attached which could lead to serious injury or death.
9. **NOTE:** Be sure to allow for adequate swing fall distances when raising the mast.
 - NOTE:** The mast must be raised to a minimum of 2ft before use. **NEVER** use the system without raising the mast to the minimum height.
10. Use the attached tagline to lower SRL connector for use. Once attached, the system is ready to use. Follow any and all directions while attached to the *X-series 1240 & 1250*.

X1250 Controller Functions

X1240 Controller Functions

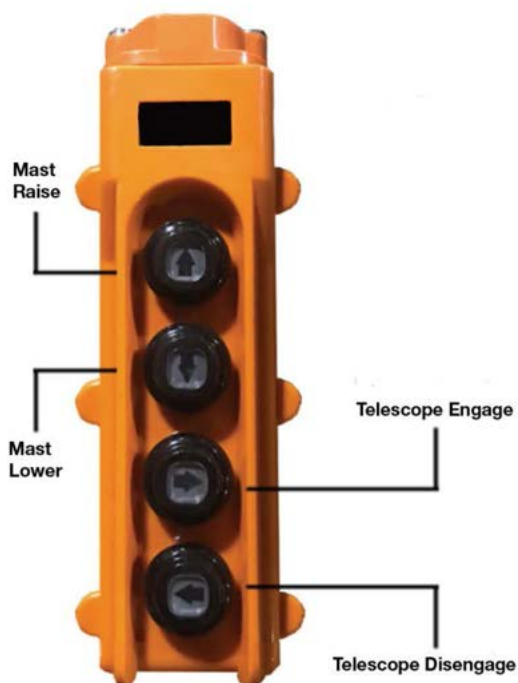
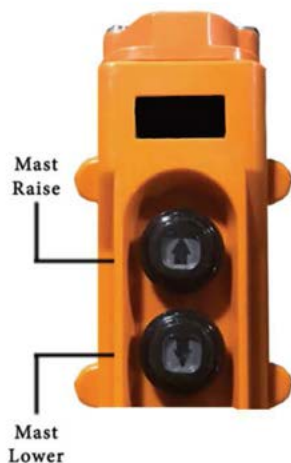

X1240 Manifold

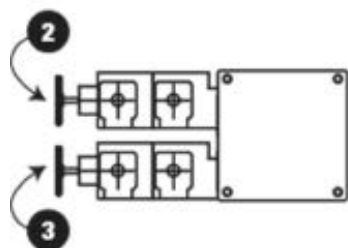

X1250 Manifold

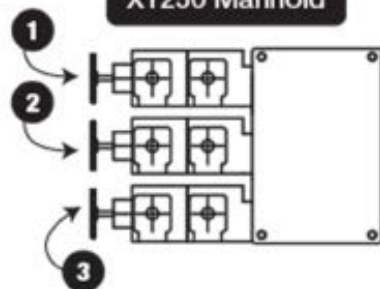

MAST SYNCING

The mast beams may become un-synced during use. Re-syncing the unit can be done while either in the fully deployed position or the fully collapsed position.

Re-sync while deployed:

1. Raise mast to full deployed height.
2. Press the same button to raise the unit and hold for 5 second bursts.
The motor will sound different; this is perfectly fine.
3. Continue these bursts until unit is fully deployed.
4. The mast is now synced.

Re-sync while compact:

1. Lower mast to full compact height.
2. Press the same button to lower unit and hold for 5 second bursts. The motor will sound different; this is perfectly fine.
3. Continue these bursts until unit is fully compact.
4. The mast is now synced.

SAFETY INSTRUCTIONS

Safety Warning Labels

You shall read and follow all instructions and safety labels for your own protection.

You must read and fully understand or have the following instructions explained to you before using this equipment. You must be properly trained prior to using this equipment. This system shall be inspected prior to each use. The *X-series 1240 & 1250* shall be inspected by a competent person other than the end user at a minimum of every 12 months.

All inquiries should be made to *Highworx* either by means of phone, or e-mail. *Highworx* shall not be held responsible for injuries the user may receive from a fall if the system or any PPE is used outside of the prescribed scope or any Industrial Code of Practice.

WARNING

The user is responsible for all maintenance and inspection records. The system must be recertified on a bi-annual basis by an authorized *manufacturer* representative or competent person.

At no time shall this unit be altered or repaired unless authorized by the manufacturer. Failure to follow the preceding instructions can result in a serious or fatal injury.

At no time shall the equipment not be used in a way or for a purpose other than as instructed by the manufacturer.

Use of components within the system must adhere to the instructions provided. Using combinations of components including but not limited to lanyards, harnesses, SRLs, and anchors in combinations is strictly prohibited.

Exposing the system to any chemical that could in any way effect its performance must be avoided. Users must contact the manufacturer for further guidance if such a situation presents itself.

Extreme caution must be used when using the system around moving machinery.

Workers must be aware and use appropriate caution when using the system around sharp edges.

INSPECTION

Inspection frequency: All systems shall be inspected visually by the user prior to each use. The unit shall be inspected by a competent person other than the end user at a minimum of every 12 months.

Detailed inspection records shall be kept. An inspection chart is provided in the owner's manual attached to the system for your convenience. In the event this system has been involved in a fall, the unit and all components must be removed from service immediately and checked by a trained and competent person before possibly being put back in service.

Systems used in harsh environments may require more frequent formal inspections. (Example: caustic or corrosive environments.)

or corrosion.

10. Ensure that the leveling jacks show no sign of wear or damage.
11. Inspect the anchor points for deformation, cracks, and that they rotate freely.
12. Make sure that all labels are present and legible.
13. Check model number
14. Serial/ VIN number is present
15. Year of manufacturing is listed
16. Purchase date listed
17. Date of first use listed
18. Due date for next inspection
19. If ANY part of this inspection does not pass, mark machine with DO NOT USE tag and contact your authorized X-series 1240 & 1250 supplier.

INITIAL QUALITY INSPECTION

(Use this form for the first inspection after receipt of system)

Inspector: _____

Purchase Date (mm/dd/yyyy): _____

System Serial No: _____

Model Number: _____

Year of Manufacture Date (yyyy): _____

Inspection Date (mm/dd/yyyy): _____

Date of First Use (mm/dd/yyyy): _____

INSPECTION ITEM	PASS	FAIL
Physical Damage to Body		
Damaged, loose, corroded, or missing hardware/connectors		
Check anchorage points are secured (mounting nuts tight) and inspect the eyes for distortion or cracks		
Check all bolts on mast are in place and secure		
Check that all labels are in place and legible		
Inspect the SRL for damage and ensure that the hook is not damaged and latch works correctly		

LIMITED WARRANTY

Malta Dynamics, LLC warrants that the Malta Dynamics Mobile Grabber shall be free from defects in material and workmanship that develop under normal use for a period of one year from the date of shipment. The foregoing shall be the exclusive remedy of the buyer and the exclusive liability of Malta Dynamics, LLC. Our warranty excludes normal replaceable wear items, i.e. gaskets, wear parts, seals, O-rings, belts, drive chains, clutches, etc. Any equipment, part or product which is furnished by Malta Dynamics, LLC but manufactured by another, bears only the warranty given by such other manufacturer (Malta Dynamics, LLC agrees to furnish free of charge a written description of problem or cause). Warranty is voided by product abuse, alterations, use of equipment in applications for which it was not intended, use of non-manufacturer parts, or failure to follow documented service instructions. The foregoing warranty is exclusive of all other warranties whether written or oral, expressed or implied. No warranty of merchantability or fitness for a particular purpose shall apply. The agents, dealers, and employees of Malta Dynamics, LLC are not authorized to make modifications to this warranty, or additional warranties binding on Malta Dynamics, LLC. Therefore, additional statements, whether oral or written, do not constitute warranty and should not be relied upon.

Malta Dynamics, LLC's sole responsibility for any breach of the foregoing warranty provisions, with respect to any product or part not conforming to the Warranty or the description herein contained, is at its option:

- a) To repair, replace, or refund such product or parts upon the prepaid return thereof to location designated specifically by Malta Dynamics, LLC. Product returns not shipped prepaid will be refused.
- b) As an alternative to the foregoing modes of settlement that dealer may repair defective units with reimbursement for expenses. A written description of problem or cause must accompany all warranty claims.

Except as set forth here in above and without limitation of the above, there are no warranties or other affirmation which extend beyond the description of the products on the fact hereof, or as to operational efficiency, product reliability, or maintainability or compatibility with products furnished by others. In no event, whether as a result of breach of contract or warranty or alleged negligence, shall Malta Dynamics, LLC be liable for special or consequential damages including but not limited to: Loss of profits or revenue, loss of use of the product or any associated product, cost of capital, cost of substitute products, facilities or services or claims of customers. Malta Dynamics, LLC does not assume responsibility for any accident due to equipment modification or misuse.

No claim will be allowed for products lost or damaged in transit. Such claims should be filed with the carrier within fifteen days.

WARRANTY REGISTRATION FORM

Submit online at www.Highworx.ie by clicking on "Contact Us" and then "Warranty Registration".

X-series 1240 & 1250 Warranty Registration

Contact: _____

Company Name: _____

Address: _____

City: _____ State: _____ Zip: _____

Phone: () _____ Fax: () _____

Email: _____

Purchased From: _____

Purchase Date: _____ Serial No: _____

Type of Industry: Rental Construction Masonry Other

Please complete this warranty registration card and return via mail or email within 30 days of purchase to validate your manufacturer's warranty for X-series 1240 & 1250 products.

Warranty provisions of this machine are handled directly through the manufacturer.



MALTA DYNAMICS

EU Declaration of Conformity

Eu Declaration of Conformity Number: 0082/2985/160/02/19/0177
Declaration Date: February, 19th 2019

Object of Declaration: X1240- Malta Dynamics Mobile Grabber
Brand Name: Mata Dynamics
Manufacturer: Malta Dynamics, LLC.
Address: 210 13th Street Malta, Ohio 43758

This declaration of conformity is under the sole responsibility of the manufacturer: Malta Dynamics, LLC.

The item of declaration is in conformity to the PPE Regulation 2016/415.

The EN 795:2012 standard was used to declare conformity to the PPE Regulation 2016/415.

The notified body APAVE SUDEUROPE SAS, CE0082 performed the EU type-examination module B and issued certificate number- 0082/2985/160/02/19/0177

The PPE is subject to the conformity assessment procedure Module C2 under the surveillance of the notified body APAVE SUDEUROPE SAS, CE0082.

This Certificate is a guarantee that the above standard(s) was met by the requirements of such standard. Testing was performed under normal operation mode. The results of testing apply only to the particular sample tested and to the specific test carried out. This Certificate is only issued for products which have passed the testing requirements of listed standard(s).

David Ivey

Product Development & Quality Manager - Malta Dynamics
Date: February, 19th 2019



EU Declaration of Conformity

Eu Declaration of Conformity Number: 0082/2985/160/02/19/0178

Declaration Date: February, 19th 2019

Object of Declaration: X1250- Malta Dynamics Mobile Grabber

Brand Name: Mata Dynamics

Manufacturer: Malta Dynamics, LLC.

Address: 210 13th Street Malta, Ohio 43758

This declaration of conformity is under the sole responsibility of the manufacturer: Malta Dynamics, LLC.

The item of declaration is in conformity to the PPE Regulation 2016/415.

The EN 795:2012 standard was used to declare conformity to the PPE Regulation 2016/415.

The notified body APAVE SUDEUROPE SAS, CE0082 performed the EU type-examination module B and issued certificate number- 0082/2985/160/02/19/0178

The PPE is subject to the conformity assessment procedure Module C2 under the surveillance of the notified body APAVE SUDEUROPE SAS, CE0082.

This Certificate is a guarantee that the above standard(s) was met by the requirements of such standard. Testing was performed under normal operation mode. The results of testing apply only to the particular sample tested and to the specific test carried out. This Certificate is only issued for products which have passed the testing requirements of listed standard(s).

David Ivey

Product Development & Quality Manager - Malta Dynamics

Date: February, 19th 2019

Notes

Notes



www.highworx.ie

www.highworx.ie

+353 (0) 1 5563424

sales@highworx.ie

Company Registration Number: 469261

VAT Number: 3556236MH